

- | | |
|--|---|
| <p>IT MONTAGGIO SYNTESIS® LINE
ESTENSIONE CARTONGESSO SP.100</p> <p>EN ASSEMBLY AND INSTALLATION
DOUBLE SYNTESIS® LINE, 100 mm
PLASTERBOARD WALL</p> <p>PT MONTAGEM SYNTESIS® LINE
ESTENSIONE PARA DE GESSO
CARTONADO ESP.100</p> <p>CZ MONTÁŽ MODELU SYNTESIS® LINE
DVOUKŘÍDLÉ SÁDROKARTON TL.100</p> <p>SK MONTÁŽ MODELU SYNTESIS® LINE
DVOJKRÍDLOVÉ DO SADROKARTÓNU
HR.100 mm</p> <p>ES MONTAJE SYNTESIS® LINE EXTENSIÓN
CARTÓN-YESO ESP.100</p> <p>NL MONTAGE SYNTESIS® LINE ESTENSIONE
GIPSKARTON DIKTE 100</p> <p>FR NOTICE DE MONTAGE DU KIT SYNTESIS®
LINE EXTENSION ÉPR.100 VERSION
PLAQUE DE PLÂTRE</p> <p>DE MONTAGEANLEITUNG FÜR SYNTESIS® LINE
DOPPELFLÜGELIG GIPSKARTON 100 mm
FERTIGE WANDSTÄRKE</p> | <p>PL MONTAŻ KASETY SYNTESIS® LINE
PODWÓJNEJ O GR.100 mm POD ZABUDOWĘ
GIPSOWO-KARTONOWĄ</p> <p>RU МОНТАЖ ECLISSE SYNTESIS® LINE
ESTENSIONE ГИПСОКАРТОН ТОЛЩ. 100</p> <p>RO MONTAJ ECLISSE SYNTESIS® LINE
ESTENSIONE GIPS CARTON GROS.
PERETE 100 mm</p> <p>SI MONTAŽA ECLISSE SYNTESIS® LINE
DVOKRILNA Z MAVČNO PLOŠČO deb.100
mm</p> <p>HU ECLISSE SYNTESIS® LINE ESTENSIONE
100-AS TOLÓAJTÓ SZERELÉSE
GIPSZKARTON FALHOZ</p> <p>HR MONTAŽA ECLISSE SYNTESIS® LINE -
DVOKRILNA GIPS PLOČA DEBLJINA 100 mm</p> <p>FI KASAUS- JA ASENNUSOHJE SYNTESIS® LINE
DOUBLE, VALMIS SEINÄPAKSUUS 100 mm,
LEVYRAKENTEINEN SEINÄ</p> <p>TR SYNTESIS® LINE ESTENSIONE
ALÇIPANEL MODELİ MONTAJI SP.100</p> <p>LT SYNTESIS DVIĞUBOS STUMDOMŲ DURŲ
KASETĖS SURINKIMAS IR MONTAVIMAS,
100 mm GIPSKARTONIO PERTVARAI</p> |
|--|---|

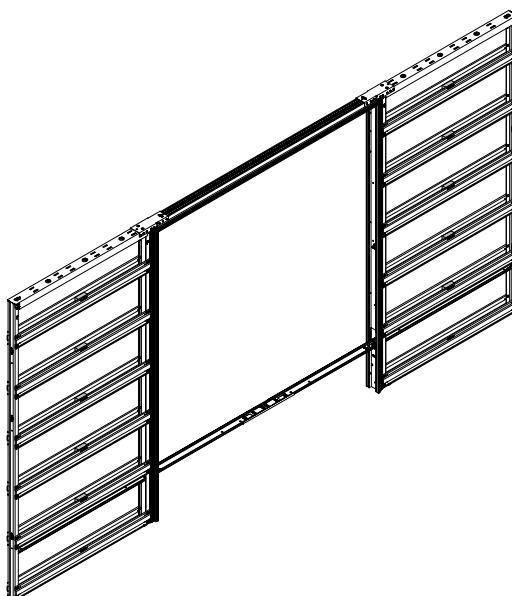

**IT**

Seguire attentamente le istruzioni.
Per un corretto montaggio, utilizzare utensili adatti come indicato e, per una corretta ergonomia, eseguire gli assemblaggi su supporti adeguati. Alcune parti dei componenti possono avere delle superfici appuntite. E' necessario quindi utilizzare adeguati dispositivi di protezione e proteggere le zone di lavoro.
"ECLISSE srl", non si assume alcuna responsabilità per danni derivati dall'uso non conforme alle presenti istruzioni.
Tutti i componenti del controtelaio sono testati e controllati in "ECLISSE srl"

EN

If you follow carefully these instructions for the assembly and installation process your life will be easier!
A pair of trestles are very useful when assembling the frames.
Some parts may have sharp edges so use gloves and be careful when handling the parts.
All Eclipse products are fully inspected and tested before they leave the factory.

BR

Seguir atentamente as instruções.
Para uma instalação correta, utilize ferramentas apropriadas conforme as instruções e, para uma ergonomia adequada, efetue as instalações utilizando suportes adequados. Algumas partes dos componentes podem ter superfícies cortantes, portanto é necessária a utilização de equipamentos de proteção adequados e é preciso proteger as áreas destinadas à execução dos trabalhos.
"ECLISSE srl", não assume qualquer responsabilidade por danos resultantes da utilização e execução que não estejam de acordo com estas instruções.
Todos os componentes do caixilho/sistema embutido são testados e controlados na "Eclipse srl"

PT

Postupujte pozorně dle pokynů.
Pro správnou instalaci používejte vhodné nástroje a s ohledem na bezpečnost práce používejte vhodné pracovní pomůcky. Některé vyrobené části mohou obsahovat ostré prvky. Proto je nutné používat odpovídající ochranné pomůcky a chránit pracovní místa. "ECLISSE srl" neodpovídá za žádné škody vyplývající z nedodržení návodu na montáž.
Všechny komponenty stavební zárubně jsou testovány a kontrolovány v "ECLISSE srl".

CZ

Dôsledne dodržiavajte návod na montáž.
Pri montáži používajte uvedenú náradie.
Kvôli správnej ergonómii a bezpečnosti pri práci odporúčame použiť montážne podpery.
Niektoré diely môžu mať ostré hrany. Používajte ochranné pracovné prostriedky.
„ECLISSE srl.“ nezodpovedá za škody spôsobené nedodržaním návodu na montáž.
Všetky komponenty puzdra sú testované a kontrolované v „ECLISSE srl.“.

SK

Seguir las instrucciones con atención.
Para un montaje correcto, utilizar las herramientas indicadas, y para una correcta funcionalidad, ensamblar en los soportes adecuados.
Algunas partes del producto pueden contener superficies punzantes y/o cortantes.
Se necesita utilizar dispositivos de protección adecuados y proteger los espacios de trabajo.
"Eclipse SRL" no asume responsabilidad alguna por los daños derivados en la utilización no conforme a estas instrucciones.
Todos los componentes del contramarco están testados y controlados en "ECLISSE SRL"

ES

Volgt u deze instructies nauwkeurig.
Gebruik voor een correcte montage geschikt gereedschap, zoals aangeraden.
Voor een correcte werkhouding adviseren wij met schragen te werken.
Sommige delen van de verschillende onderdelen kunnen scherpe kanten hebben, daarom is het noodzakelijk om de juiste bescherming te dragen en de werkruimte te beschermen.
"ECLISSE srl" is niet aansprakelijk voor schade die ontstaan is door het niet opvolgen van deze instructies.
Alle delen van het frame zijn volledig geïnspecteerd en getest door "ECLISSE srl".

NL

Suivre scrupuleusement les instructions
Afin de réaliser un assemblage correct, choisir un support adapté et utiliser les outils appropriés comme indiqué sur la notice.
Quelques éléments du produit peuvent avoir des parties pointues ou coupantes, il est donc nécessaire d'utiliser des protections corporelles efficaces et sécuriser l'espace de montage.
ECLISSE décline toute responsabilité pour tous dommages provoqués par le non respect de ces règles.
Tous les composants du produit sont testés et vérifiés par ECLISSE SRL.

FR

Followen Sie genau der Montageanleitung
Für die korrekte Montage, verwenden Sie die angegebenen passenden Werkzeuge.
Für die korrekte Ergonomie, sollten die Montagearbeiten auf passende Arbeitsflächen ausgeführt werden.
Einige der Bauteile können spitze Oberflächen haben. Es ist notwendig passende Schutzvorrichtungen zu verwenden und die Arbeitsfläche schützen.
„Eclipse Srl“ übernimmt keine Verantwortung für Beschädigungen, die durch Nichtbeachtung der Montageanleitung hervorgerufen werden.
Wandöffnung nach DIN 18183-1 erstellen
Alle Bauteile des Einbaukastens wurden in „Eclipse“ geprüft und getestet.

DE

Postępować zgodnie z instrukcją montażu.
W celu wykonania prawidłowego montażu, używać odpowiednich narzędzi, zgodnych ze wskazaniami, a dla zapewnienia odpowiedniej ergonomii przy dokonaniu montażu stosować odpowiednie podpory. Powierzchnia niektórych elementów składowych może być ostra. W związku z tym koniecznym jest stosowanie odpowiednich środków ochrony indywidualnej oraz zabezpieczenie obszaru pracy. Eclipse SRL uchyla się od poniesienia jakiegokolwiek odpowiedzialności za poniesione szkody wynikające z postępowania niezgodnego z niniejszą instrukcją.
Wszelkie części składowe asortymentu Eclipse SRL są testowane w wewnętrznym laboratorium.

PL

Пожалуйста, строго следуйте инструкциям.
Для правильной установки пользоваться соответствующим оборудованием как указано, для правильной эргономики сделать монтаж на надежных основах. Некоторые части могут иметь заостренные концы, в связи с чем следует использовать соответствующим предохранительным устройством и защитить рабочую зону.
«ECLISSE srl» не несет ответственности за ущерб, ставший следствием несоблюдения правил, содержащихся в данной инструкции.
Все компоненты пенала проходят необходимую проверку в фирме «"ECLISSE srl"».

RU

Urmați cu atenție instrucțiunile de montaj.
Pentru un montaj corect, folosiți ustensile potrivite, iar pentru o ergonomie adecvată, asamblarea se face pe suporturi corespunzătoare, urmând metodele indicate. Unele părți ale componentelor pot avea suprafețe ascuțite. Prin urmare, este necesar să se folosească echipamente de protecție și să se asigure zona de lucru.
ECLISSE EST SRL nu își asumă nici o responsabilitate pentru daunele survenite ca rezultat al nerespectării prezentelor instrucțiuni.
Toate componentele din structura cadrului metalic sunt testate și controlate în fabrică.

RO

Če boste pažljivo prebrali in upoštevali dana navodila za sestavo in montažo podboja bo bistveno enostavneje.
Priporočljiva je uporaba rokavic zaradi morebitnih ostrih robov in previdno rokujte z izdelkom. Vsi Eclipse izdelki so pod stalno kontrolo in testirani preden zapustijo tovarno.

SI

Az összeszerelésnél figyelmesen kövesse a beépítési útmutatót!
Szerelőbák haszálata megkönyvít az összeszerelést.
Az éles szélék sérülést okozhatnak, ezért használon védőkesztyűt az összeszerelésnél.
Minden Eclipse termék minőségellenőrzésen esik át forgalomba kerülés előtt.

HU

Pažljivo slijedite upute.
Za pravilnu montažu, koristite odgovarajući alat kao što je navedeno, a za postizanje pravilnog ergonomskog položaja, montirajte dijelove na odgovarajuće nosače. Površine pojedinih sastavnih dijelova mogu biti zaostrene. Stoga je potrebno koristiti odgovarajuću zaštitnu opremu i zaštititi područja rada.
"ECLISSE srl" ne preuzima nikakvu odgovornost za štete prouzročene korištenjem koje nije u skladu s ovim uputama.
Svi sastavni dijelovi okova za vrata su ispitani i provjereni u "ECLISSE srl"

HR

Noudata näitä kokoamis- ja asennusohjeita tarkasti.
Kehysten kokoamisessa kannattaa käyttää apuna pukkeja.
Käytä suojakäsineitä, sillä osien reunat voivat olla teräviä.
Kaikki Eclipse-tuotteet tarkastetaan ja testataan tehtaalla ennen toimittamista.

FI

Eğer bu talimatları dikkatle takip ederseniz, montaj ve kurulum için işiniz daha kolay olacaktır.
Çerçevenin montajını yaparken, bir çift kasanın kullanılması çok faydalı olur.
Bazı parçalar keskin kenarlara sahip olabilir, bu nedenle eldiven kullanılmı ve parçaların tutarken daha dikkatli olunmalıdır.
Eclipse'nin tüm ürünleri fabrika çıkışından önce kontrol edildi ve test edildi.

TR

Jeigu tiksliai vadovausitės šiomis surinkimo ir montavimo instrukcijomis, jūsų gyvenimas bus lengvesnis. Staktą surinkite ant tinkamo pagrindo. Kai kurios staktos dalys gali būti aštrios, tad būkite pirštines ir būkite atsargūs keldami staktą ar jos dalis.
Visi Srl Eclipse gaminiai yra visiškai išbandyti ir patikrinti.

LT

Hvis du følger disse samle instruktioner og montage, vil din oplevelse være succesfuld.
Et par handsker er meget nyttige, når du monterer rammen. Nogle dele kan have skarpe kanter, så brug handsker, og vær forsigtig, når du håndterer delene.
Alle Eclipse-produkter er fuldt inspiceret og testet, inden de forlader fabrikken.

DK

Hvis du følger disse installasjons- og monteringsanvisningene nøye, vil det hele bli mye enklere!
Et par hansker er veldig nyttige når du skal montere rammene.
Noen deler kan ha skarpe kanter, så bruk hansker og vær forsiktig når du håndterer delene.
Alle Eclipse-produkter er fullstendig inspisert og testet før de forlater fabrikken.

NO

Om du följer dessa installations- och monteringsanvisningar noggrant blir det hela mycket enklare! Ett par handskar är mycket användbart vid montering av ramarna. Vissa delar kan ha vassa kanter, så använd handskar och var försiktig när du hanterar delarna. Alla Eclipse-produkter är inspekterade och testade innan de lämnar fabriken.

SE

- 2 -

ATTREZZATURA NECESSARIA PER IL MONTAGGIO
TOOLS REQUIRED
EQUIPAMENTOS NECESSÁRIOS PARA A MONTAGEM
NÁŘADÍ POTŘEBNÉ K MONTÁŽI
NÁRADIE POTREBNÉ NA MONTÁŽ
HERRAMIENTAS NECESARIAS PARA EL MONTAJE
BENODIGD GEREEDSCHAP
OUTILS NECESSAIRES POUR L'ASSEMBLAGE
NOTWENDIGES WERKZEUG ZUR AUSFÜHRUNG DER MONTAGE
OPRZYRZĄDOWANIE POTRZEBNE DO MONTAŻU
НОЕОБХОДИМОЕ ДЛЯ УСТАНОВКИ ОБОРУДОВАНИЕ
ECHIPAMENTE NECESARE PENTRU MONTAJ
PRIPOROČLJIVO ORODJE
SZÜKSÉGES ESZKÖZÖK
ALAT POTREBAN ZA MONTAŽU
TARVITAVAT VÄLINEET
GEREKLİ ARAÇLAR
SURINKIMUI IR MONTAVIMUI REIKALINGI ĮRANKIAI
NØDVENDIGE VÆRKTØJ
NØDVENDIG VERKTØY
VERKTYG SOM KRÄVS

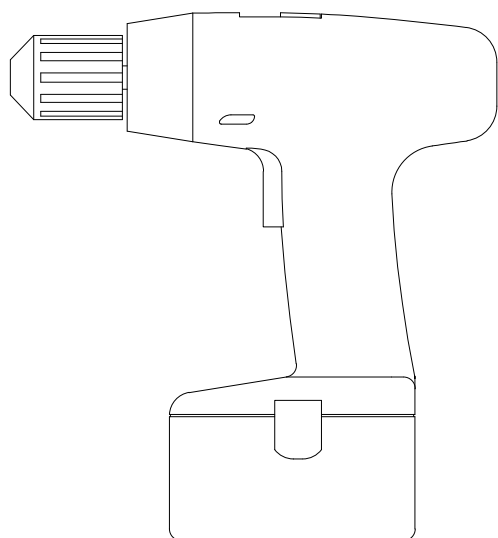

EN388

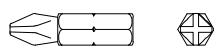
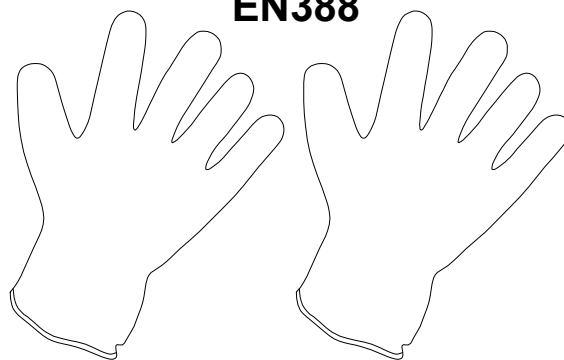

PH2

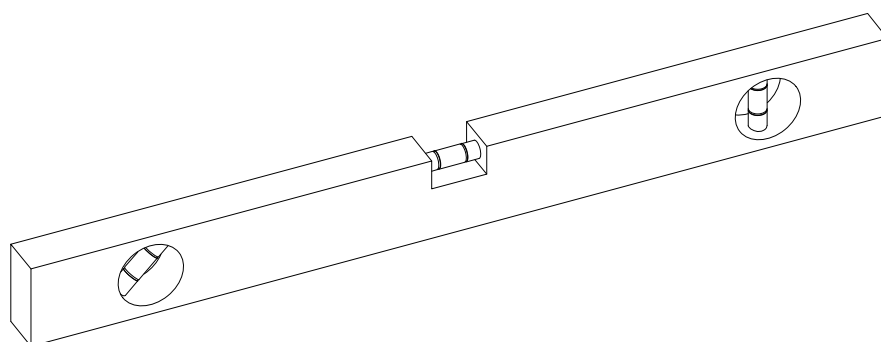
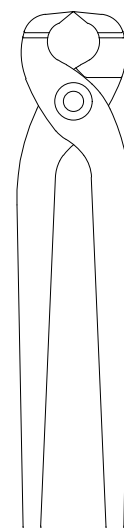
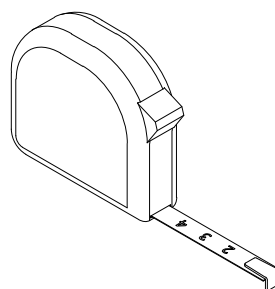

COMPONENTI / COMPONENTS / COMPONENTES / KOMPONENTY / KOMPONENTY /
 COMPONENTES / ONDERDELEN / COMPOSANTS / BAUTEILE / CZĘŚCI / КОМПОНЕНТЫ /
 COMPONENTE / SESTAVNI DELI / ALKATRÉSZEK / SASTAVNI DIJELOVI / OSAT / BİLEŞENLER /
 KOMPONENTAI / KOMPONENTER

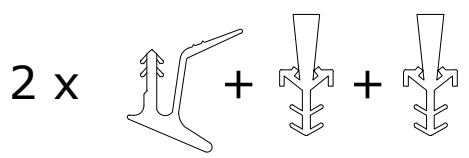
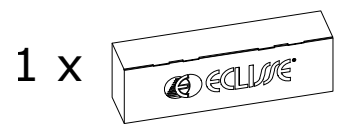
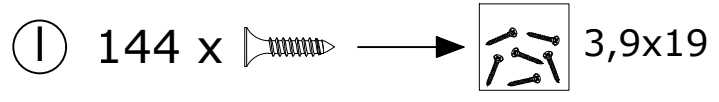
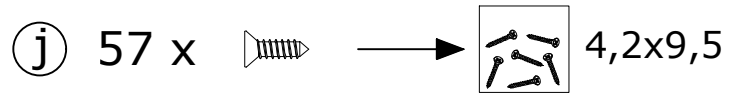
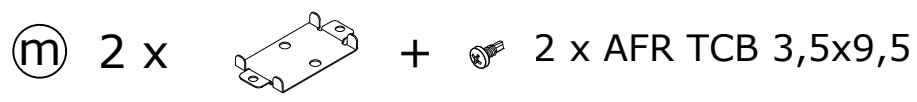
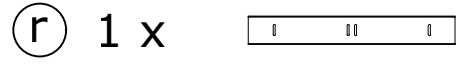
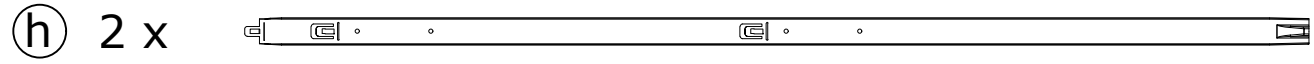
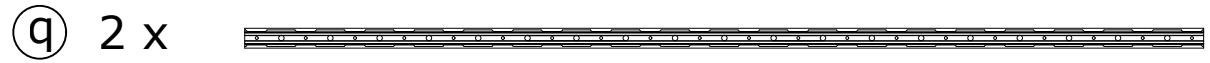
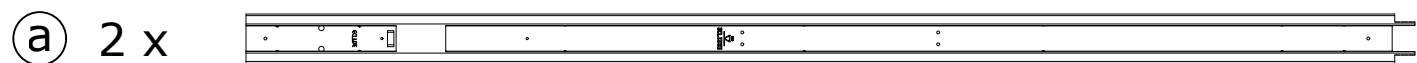

1 x 2

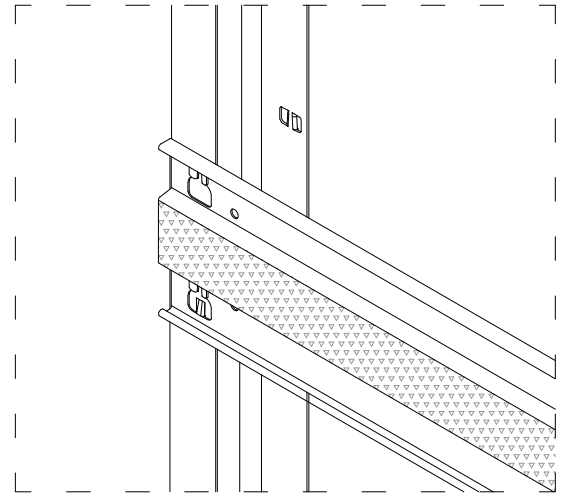
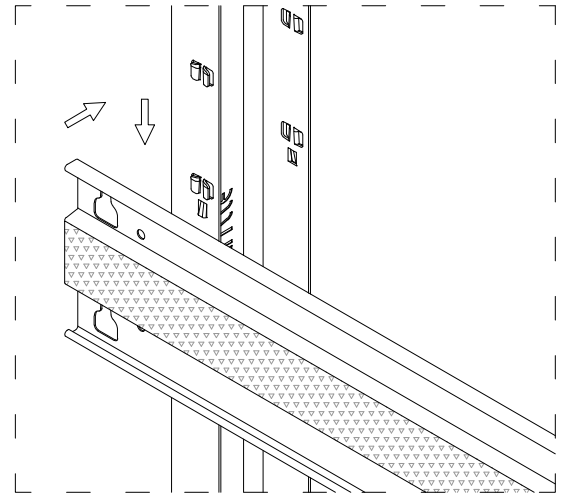
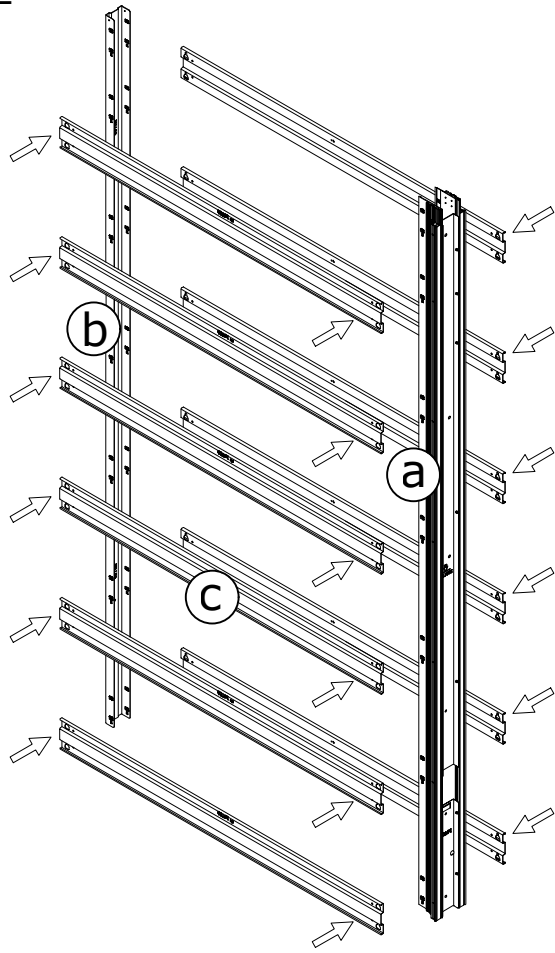

2 x 2

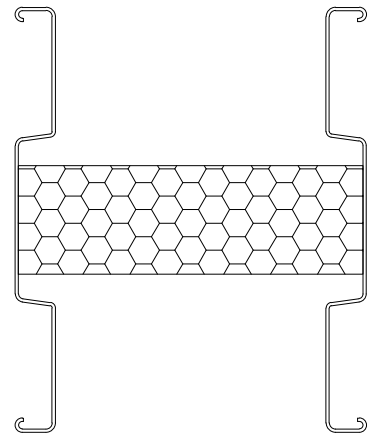
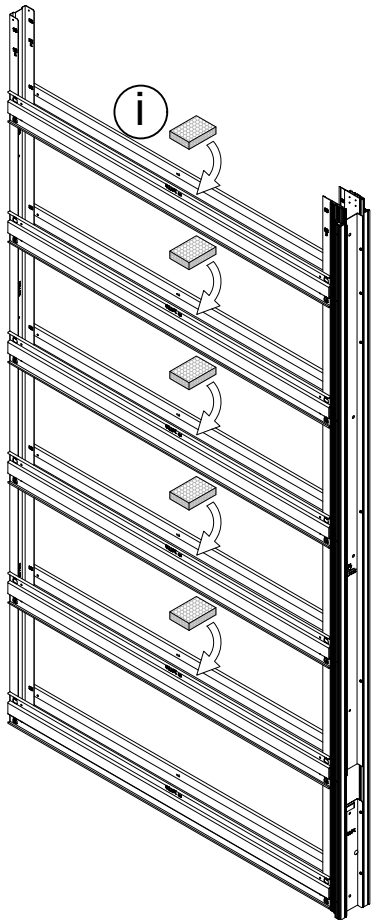

3 x 2

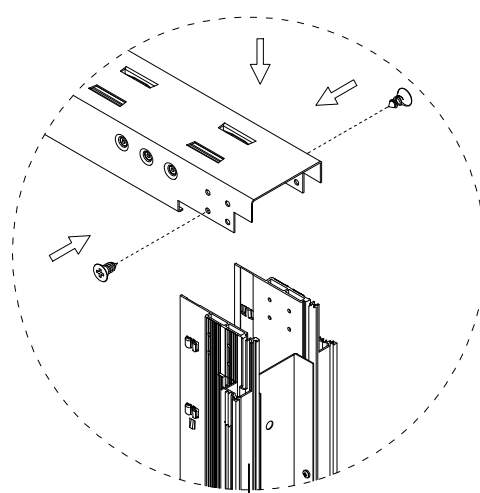
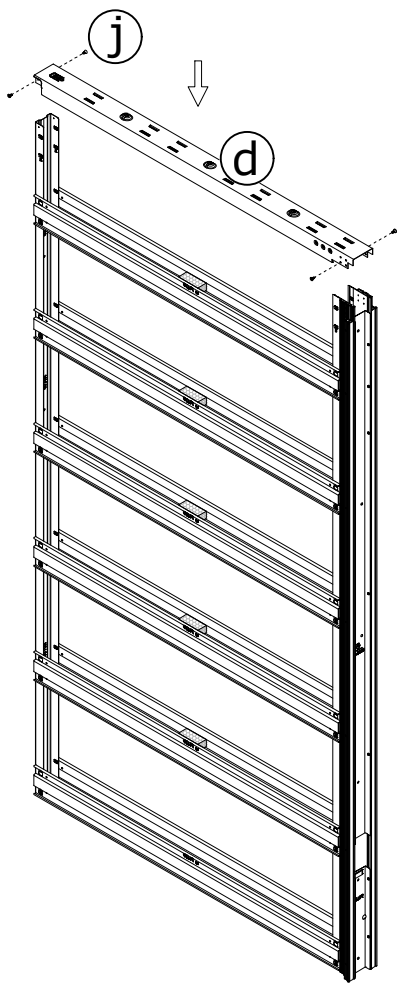

4,2x9,5

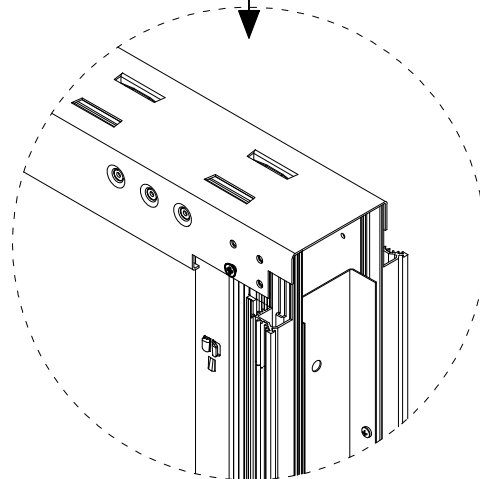

4 x 2

3,5x9,5

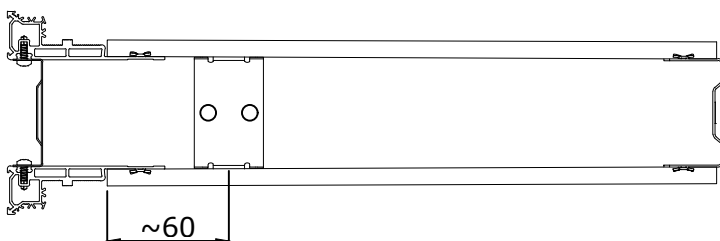
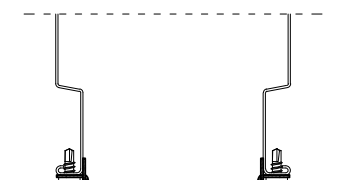
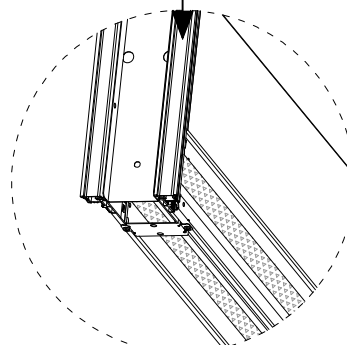
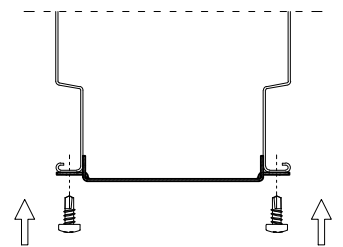
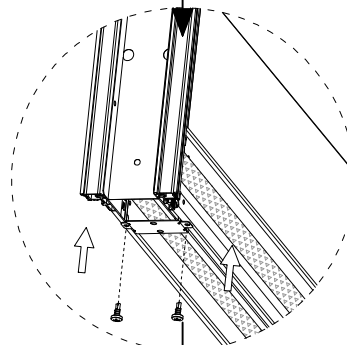
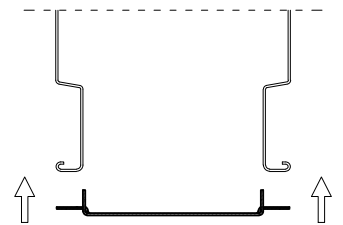
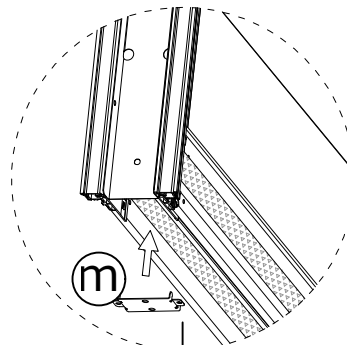
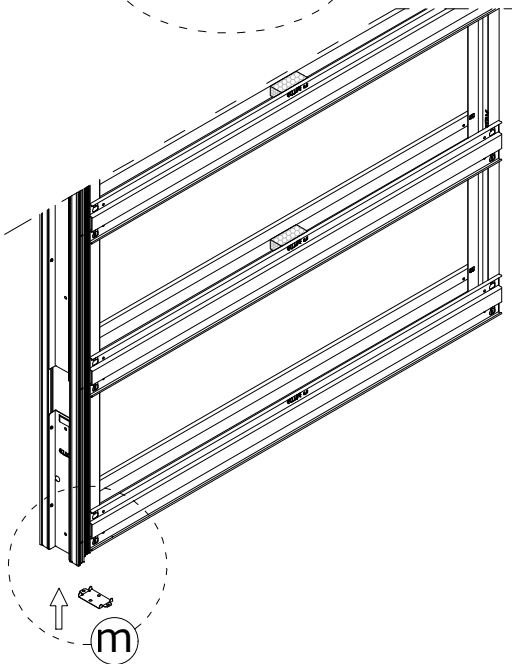

5

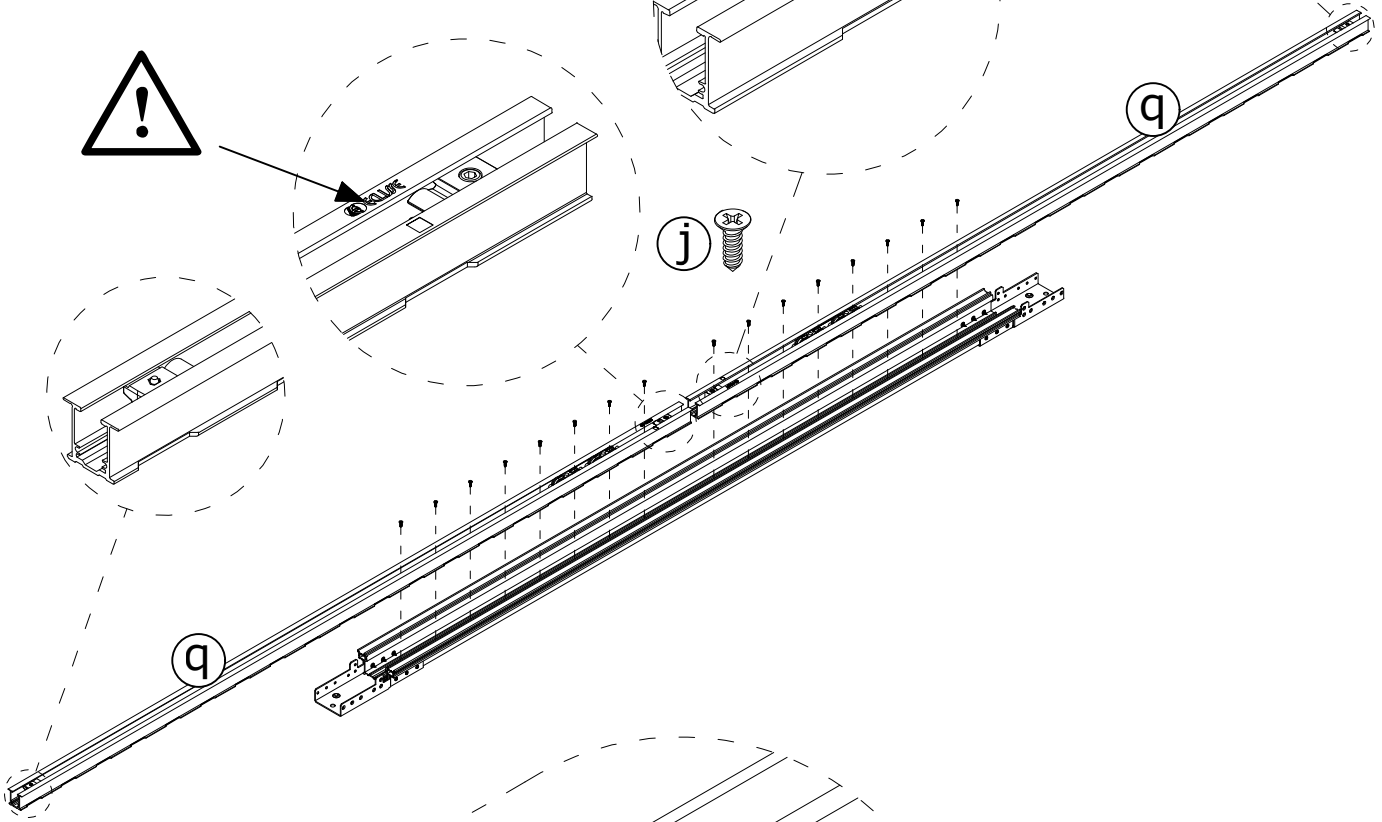
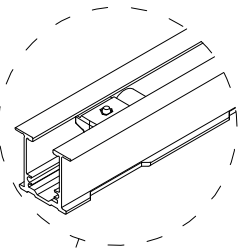
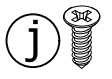
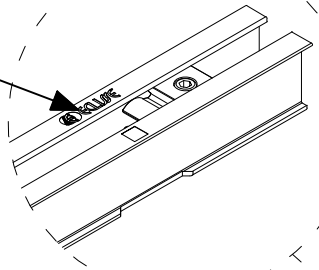
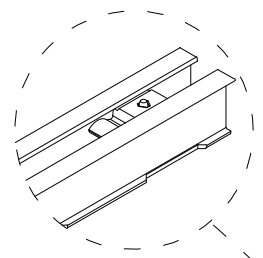
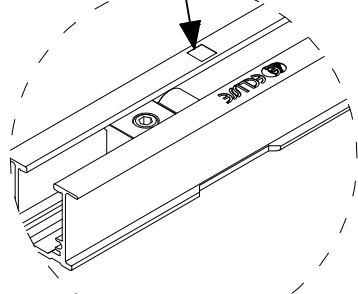
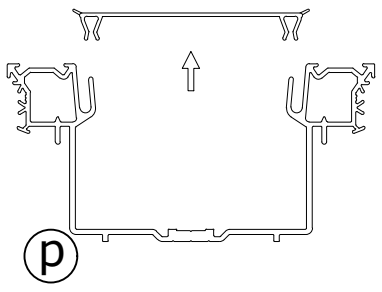

~ 50 mm

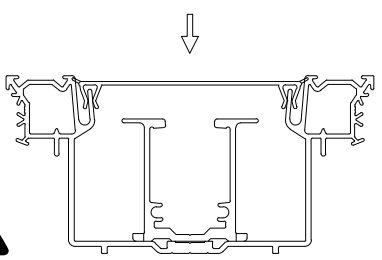
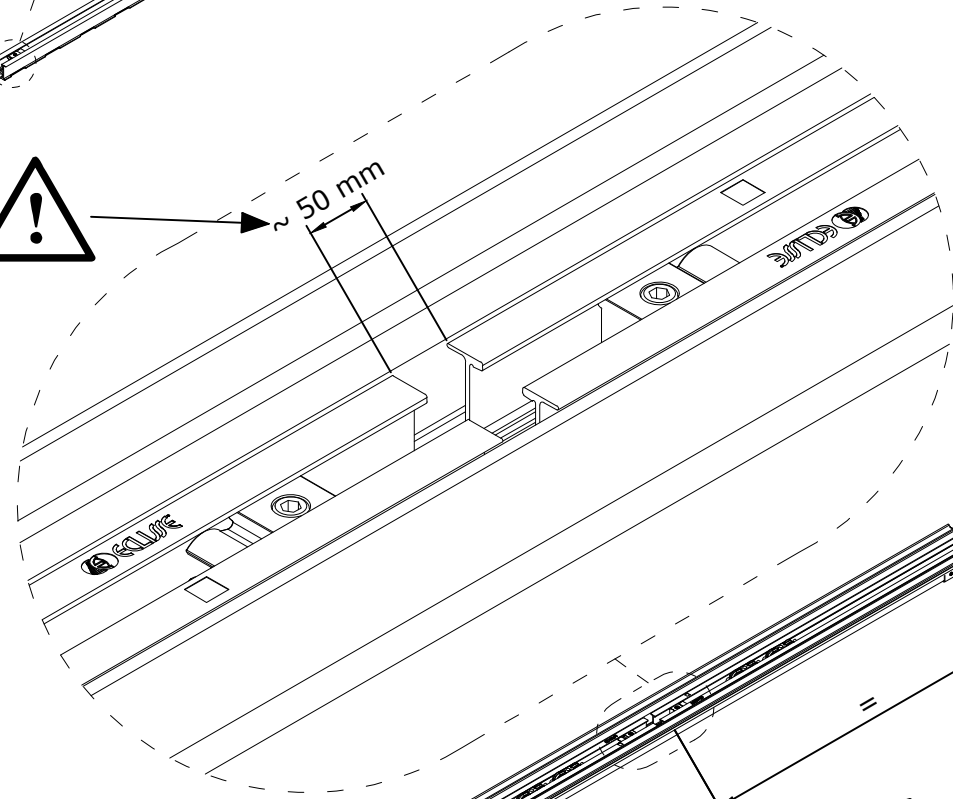

6

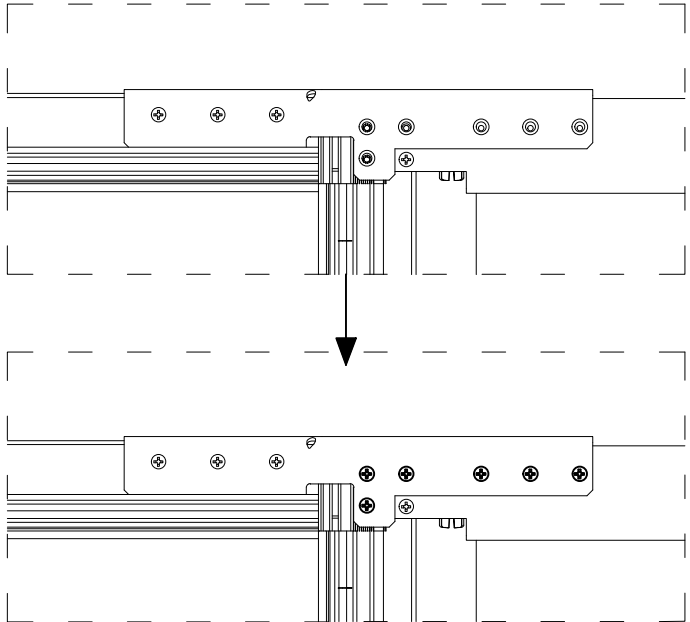
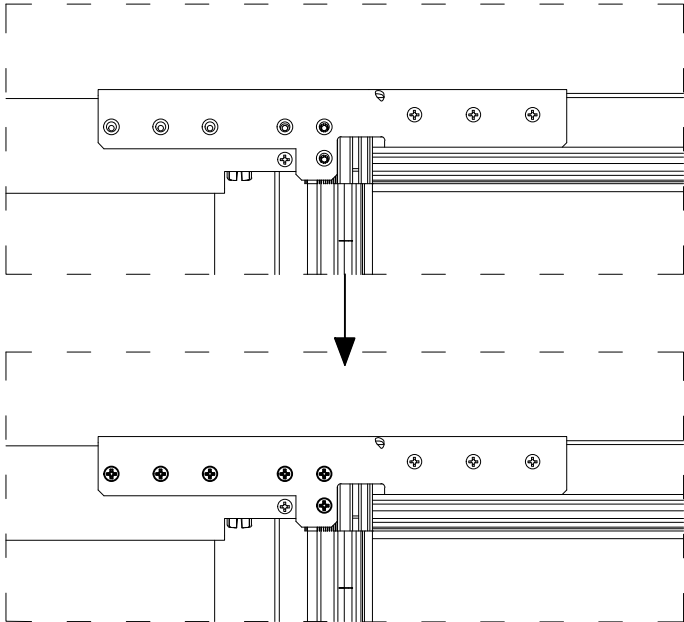
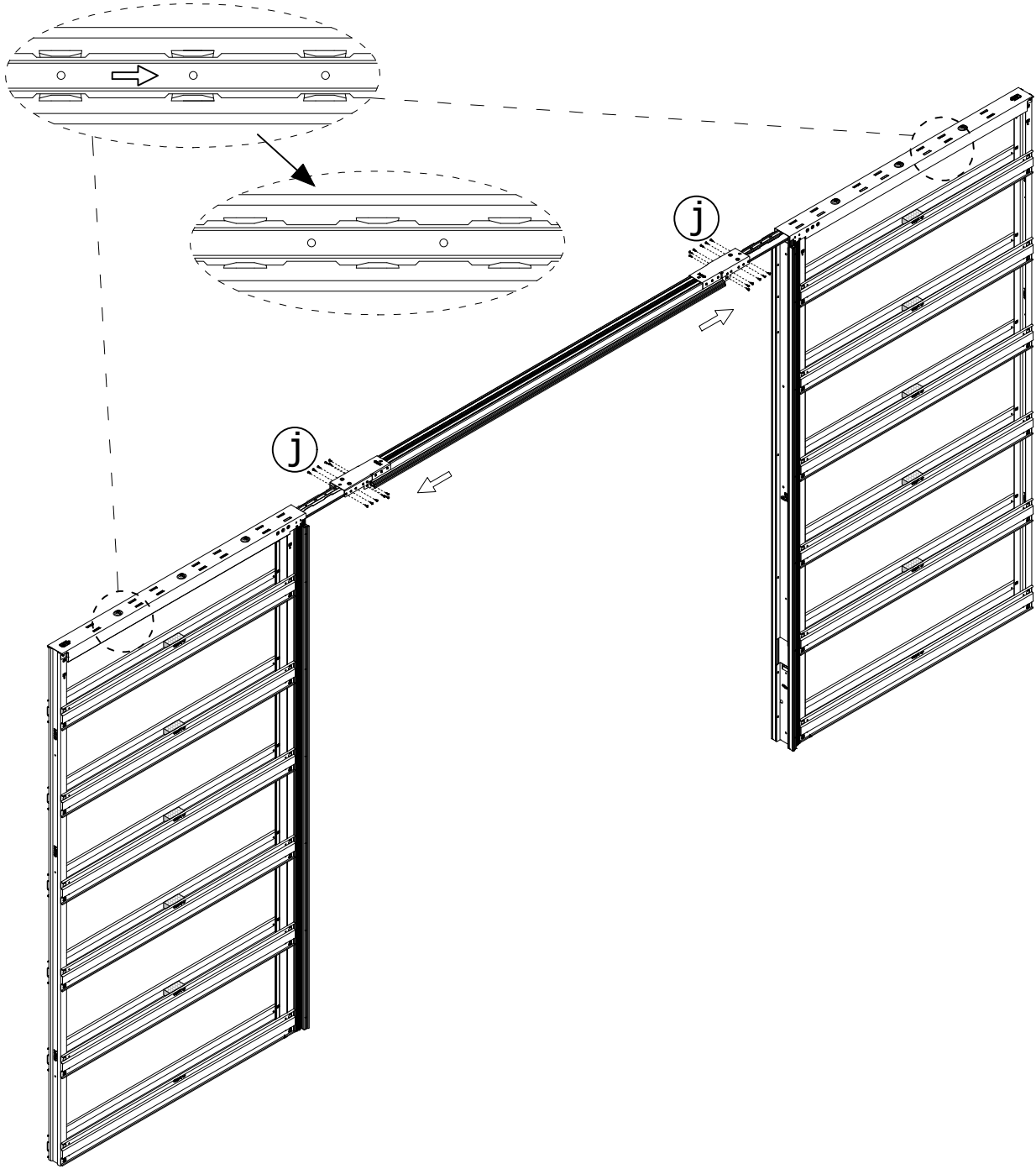

7 x 2

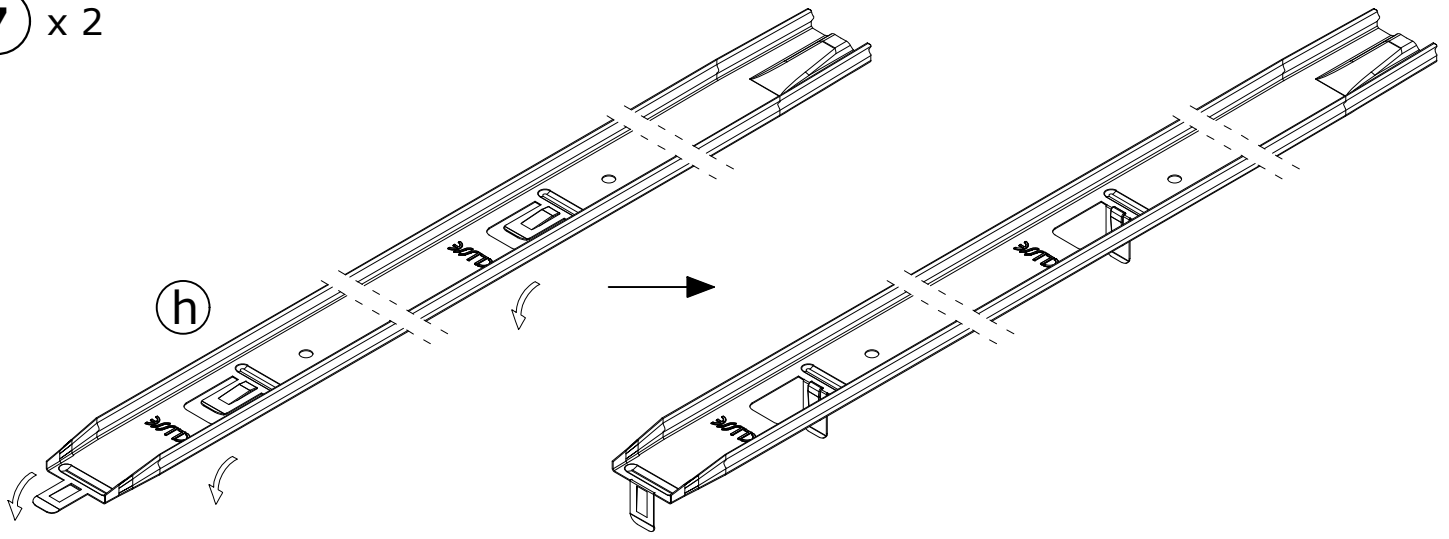

8

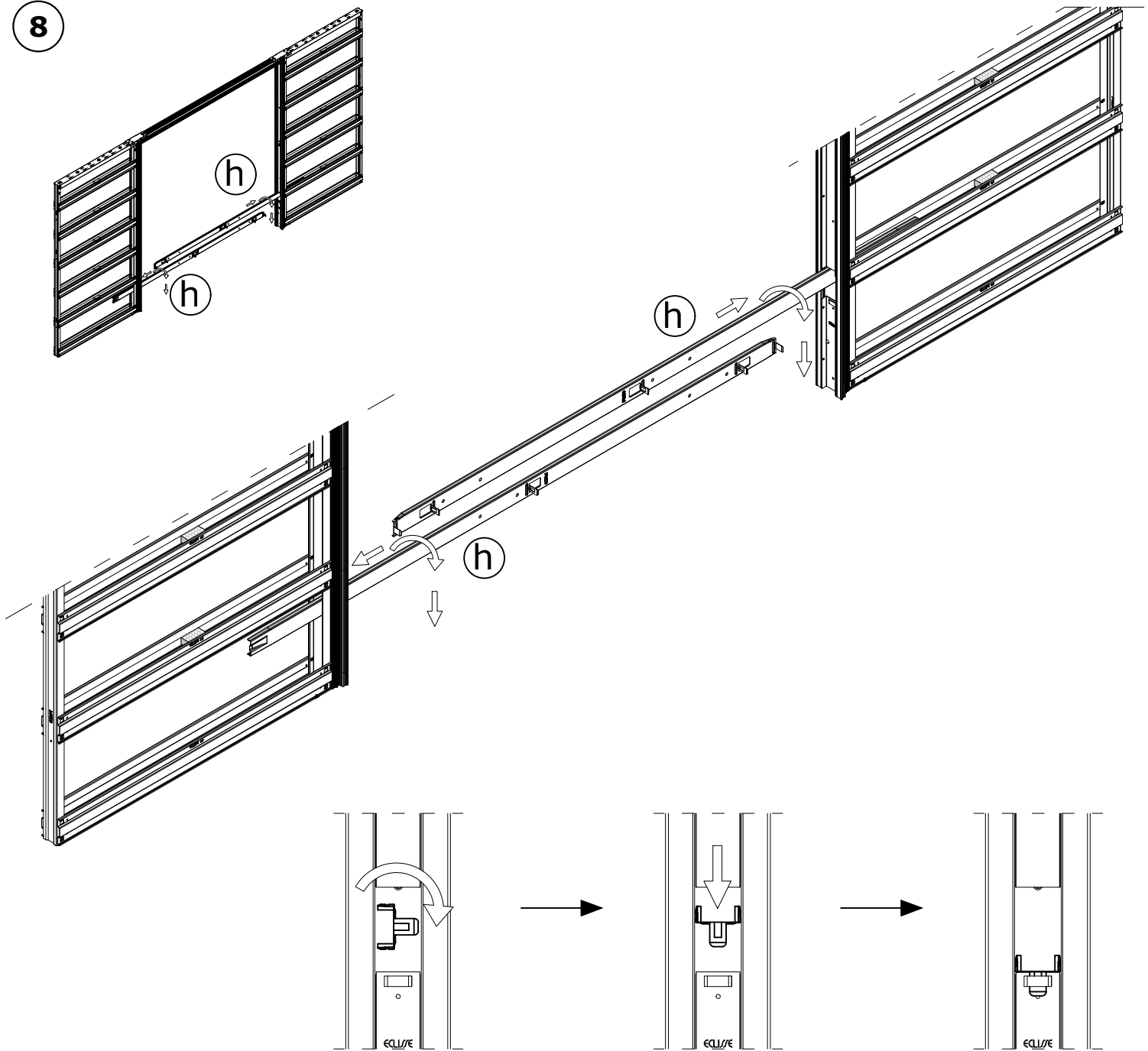

9

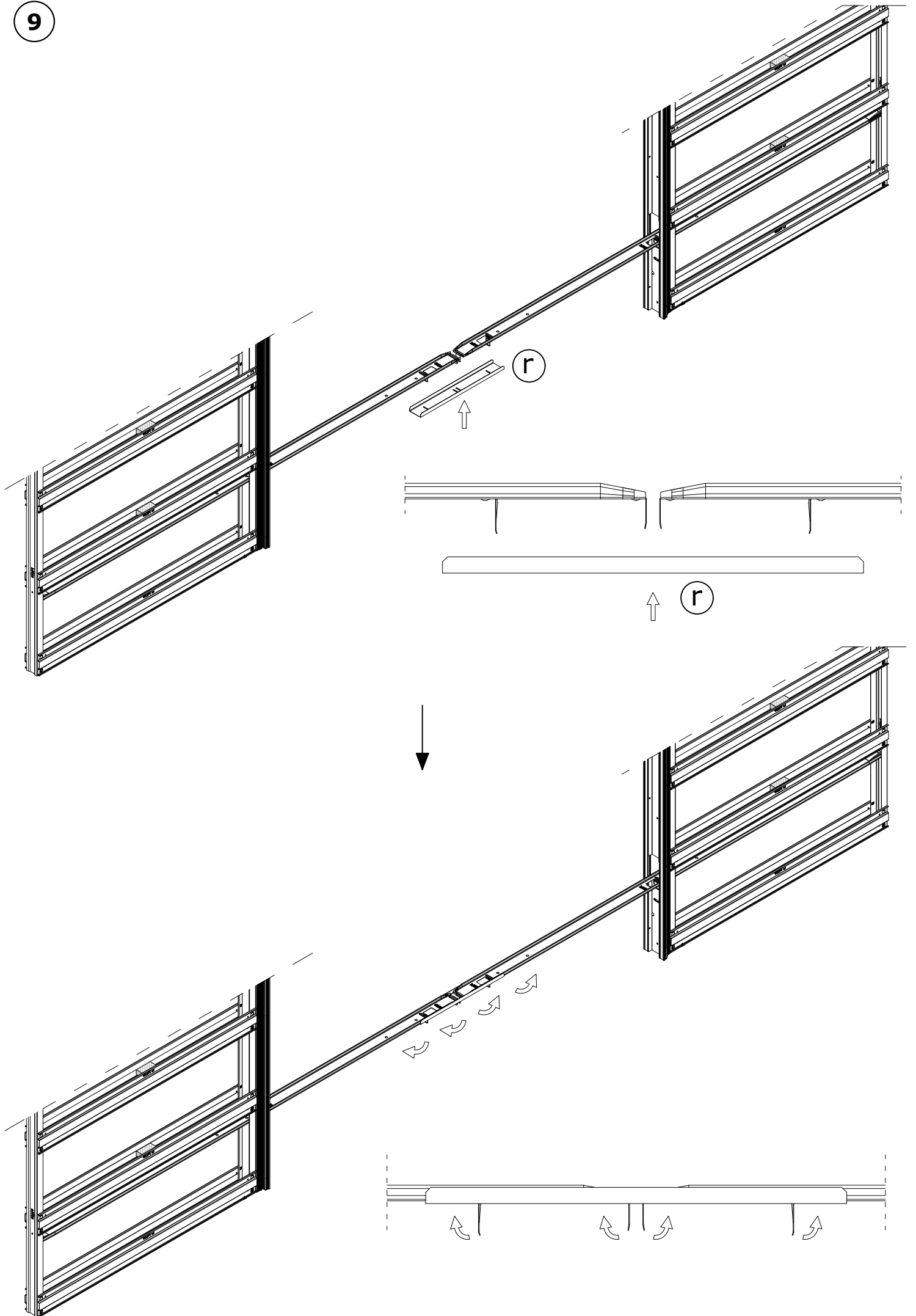

10 SOLUTION 1

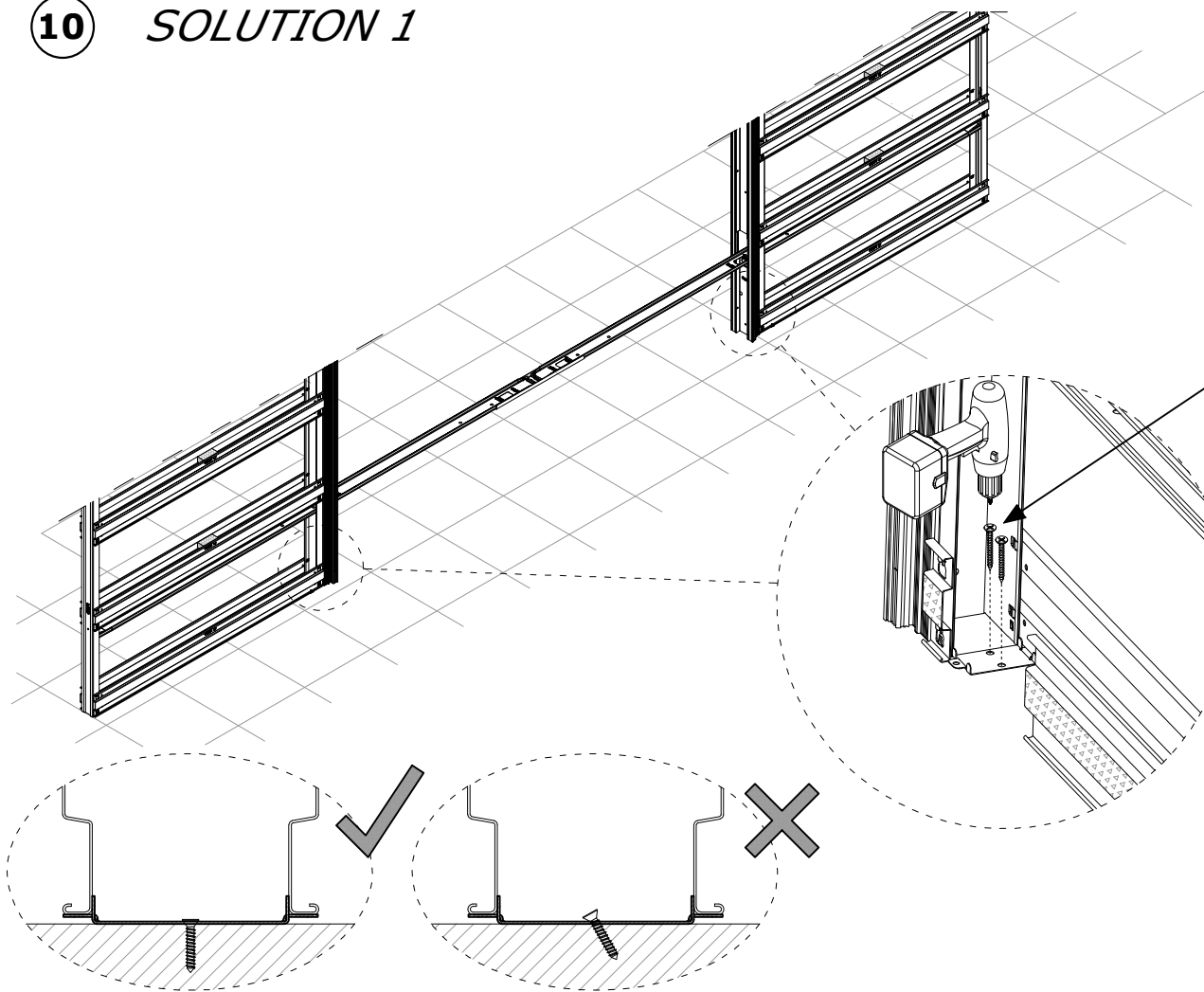

- Ⓜ PEZZO NON FORNITO
- Ⓔ NOT SUPPLIED
- Ⓟ PEÇA ÑAO PORNECIDA
- ⒸZ NENÍ SOUČÁSTÍ BALENÍ
- Ⓚ NIE JE SÚČASŤOU BALENIA
- ⒺS PIEZA NO SUMINISTRADA
- ⓃL NIET BIJGESLOTEN
- ⒻR PIÈCE NON FOURNIE
- ⒹE NICHT IM LIEFERUMFANG
- ⓅL CZĘŚĆ NIE FORNIROWANA
- ⓇU ДЕТАЛЬ НЕ ПОСТАВЛЯЕТСЯ
- ⓇO PIEŠĀ NEFURNIZATĀ
- ⓈI NI DOBAVLJENO
- ⒽU NEM TARTOZÉK
- ⒽR DIO KOJI NIJE DOSTAVLJEN
- ⒻI TOIMITUKSEEN
- ⒻI SISÄLTYMÄTTÖMÄT OSAT
- ⒽR KUTU İÇİNDE YOKTUR
- ⒻT NEĮSKAIČIUOTA Į KOMPLEKTA

SOLUTION 2

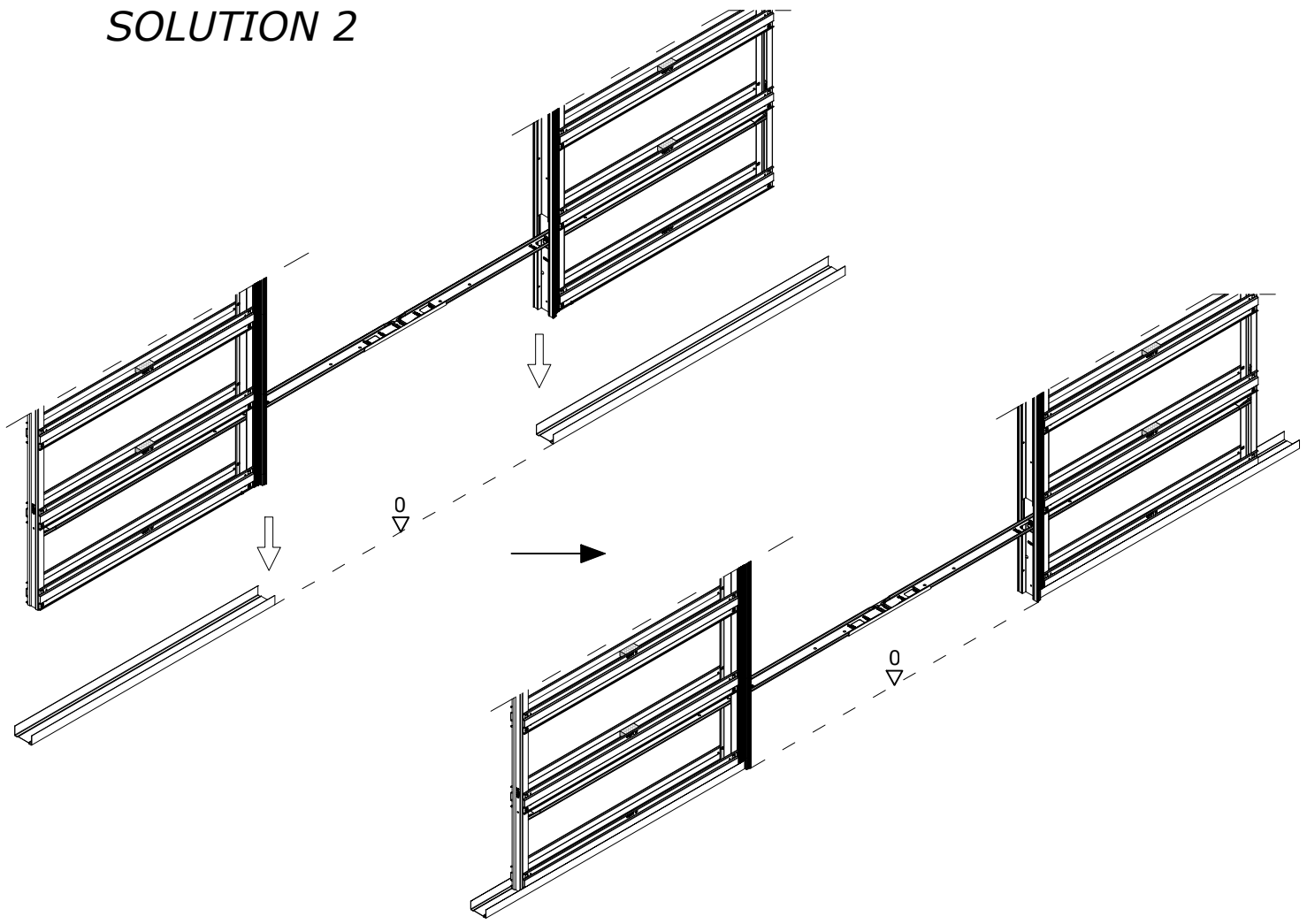

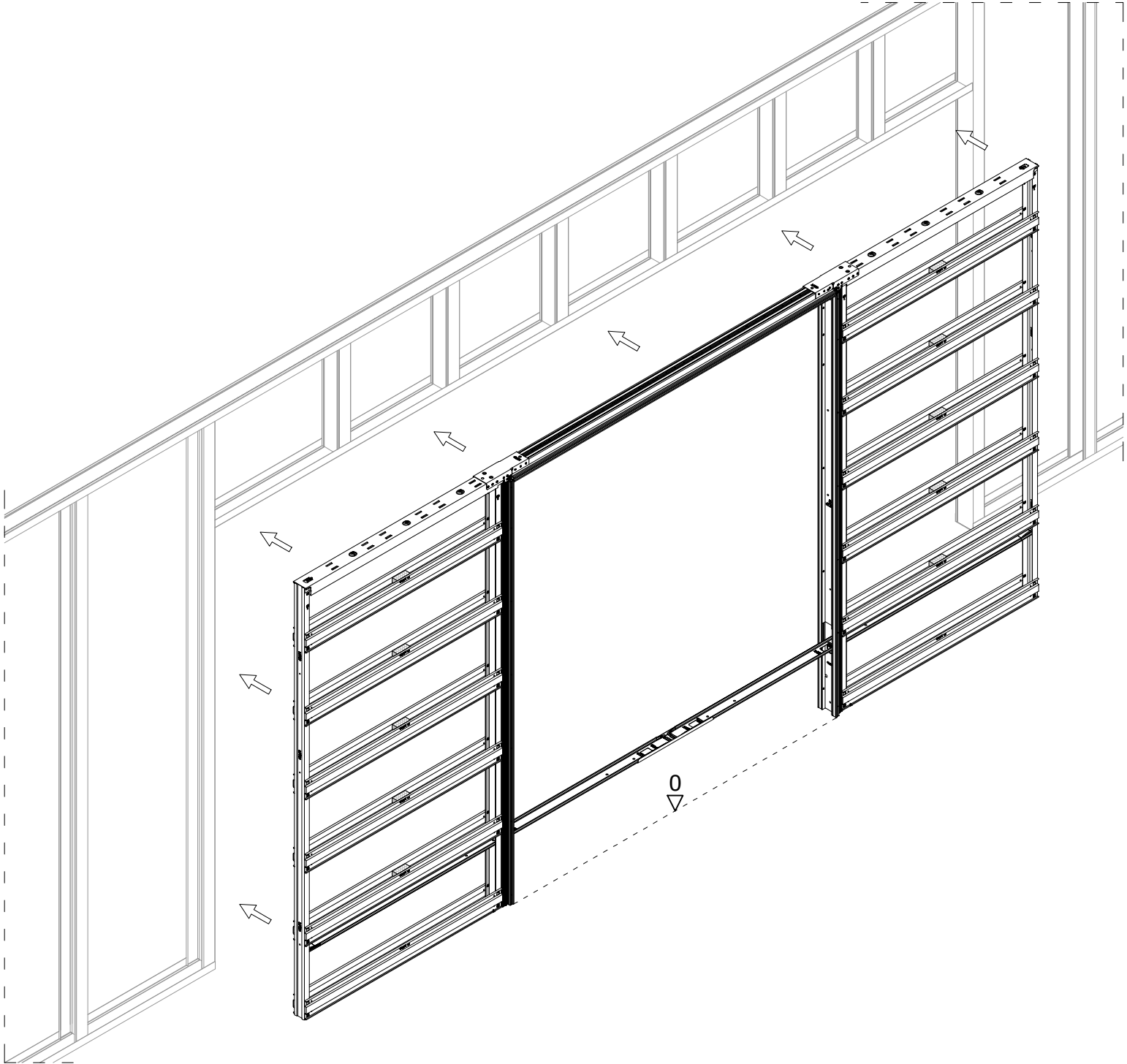

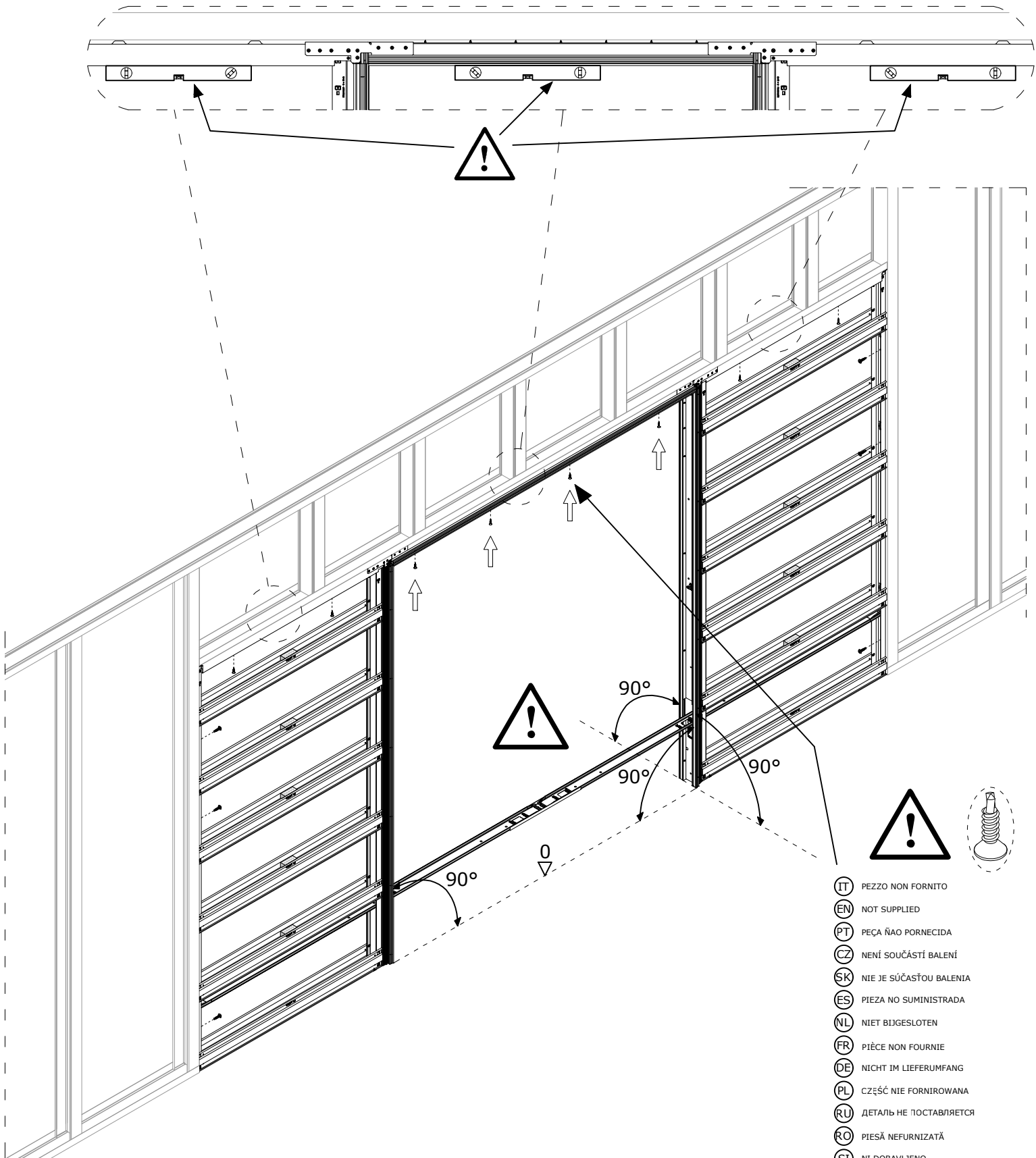

- Ⓜ IT PEZZO NON FORNITO
- Ⓜ EN NOT SUPPLIED
- Ⓜ PT PEÇA ÑAO PORNECIDA
- Ⓜ CZ NENÍ SOUČÁSTÍ BALENÍ
- Ⓜ SK NIE JE SÚČASŤOU BALENIA
- Ⓜ ES PIEZA NO SUMINISTRADA
- Ⓜ NL NIET BIJGESLOTEN
- Ⓜ FR PIÈCE NON FOURNIE
- Ⓜ DE NICHT IM LIEFERUMFANG
- Ⓜ PL CZĘŚĆ NIE FORNIROWANA
- Ⓜ RU ДЕТАЛЬ НЕ ПОСТАВЛЯЕТСЯ
- Ⓜ RO PIEȘĂ NEFURNIZATĂ
- Ⓜ SI NI DOBAVLJENO
- Ⓜ HU NEM TARTOZÉK
- Ⓜ HR DIO KOJI NIJE DOSTAVLJEN
- Ⓜ FI TOIMITUKSEEN SISÄLTYMÄTTÖMÄT OSAT
- Ⓜ TR KUTU İÇİNDE YOKTUR
- Ⓜ LT NEĮŠKAIČIUOTA Į KOMPLEKTĄ

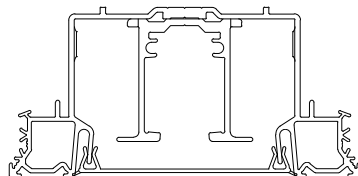
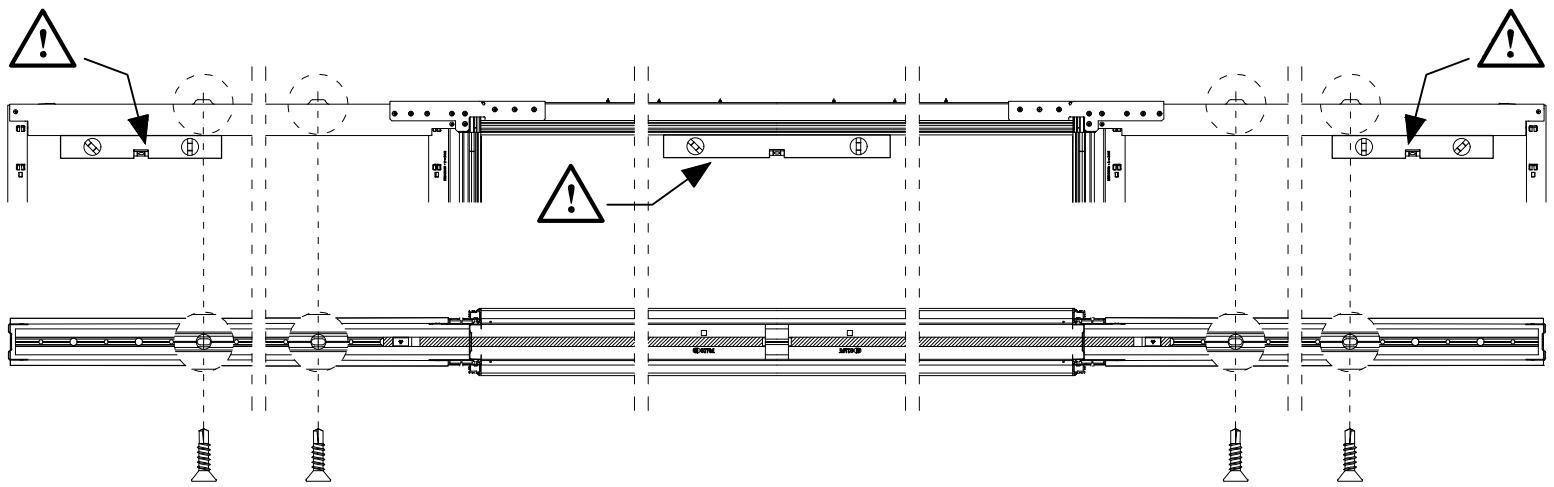
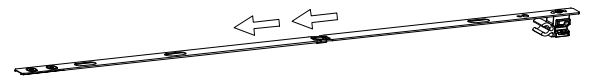
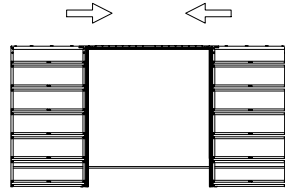
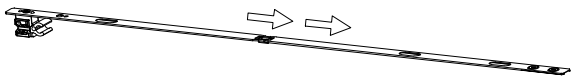
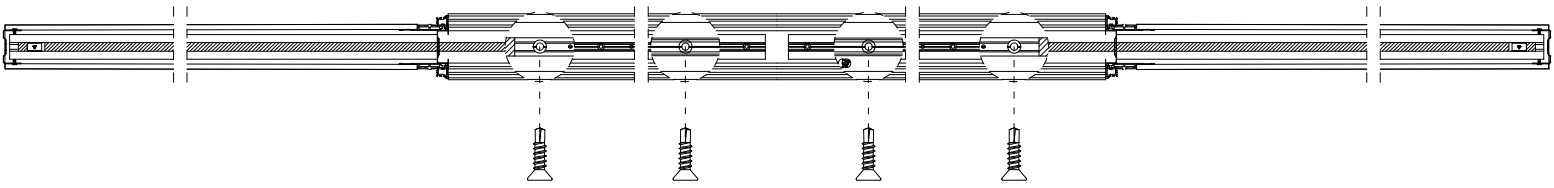
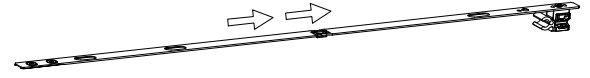
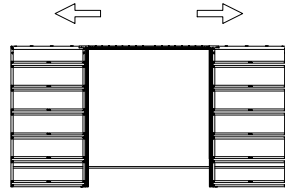
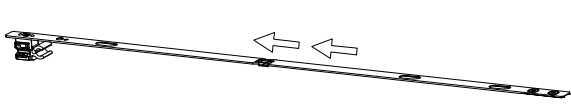
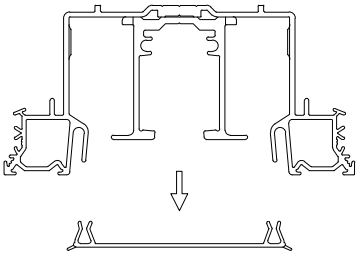

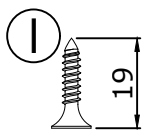
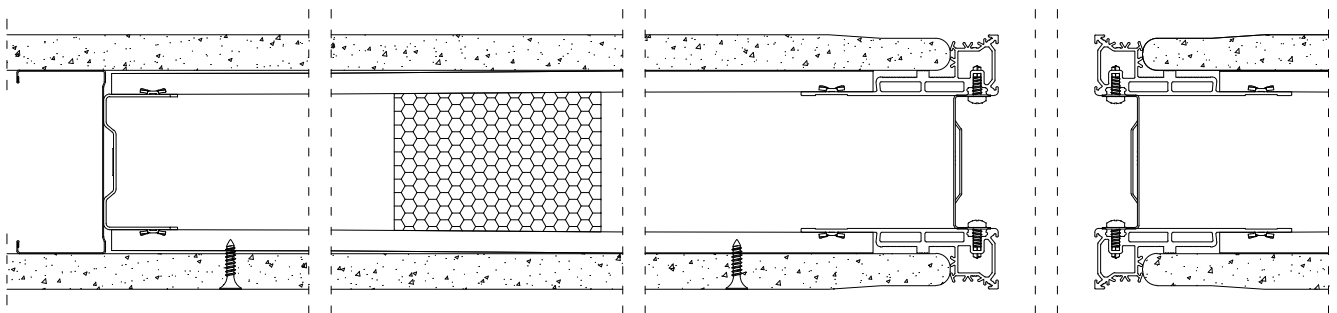
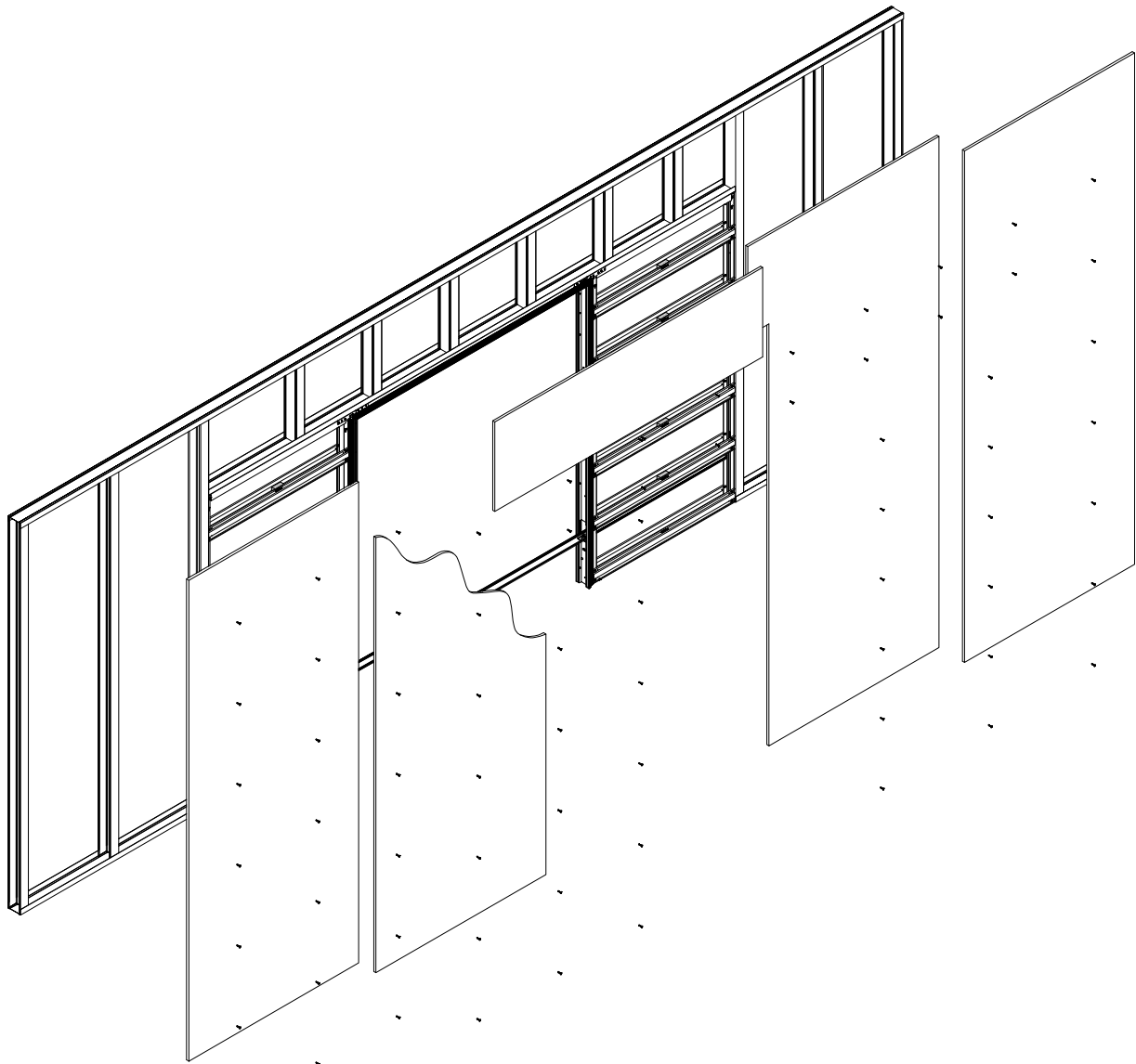

3,9x19

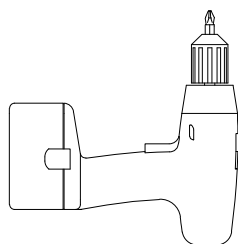

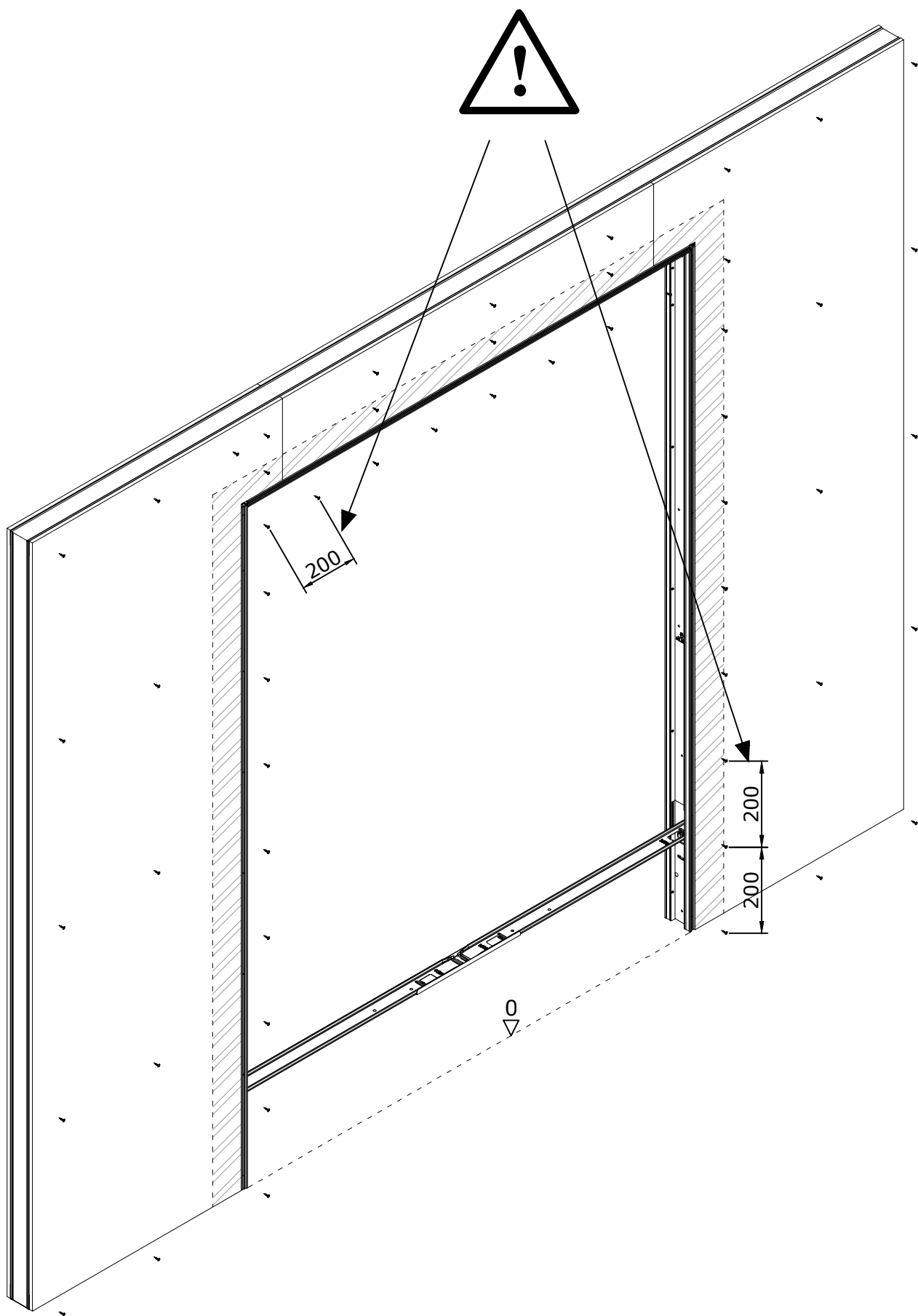

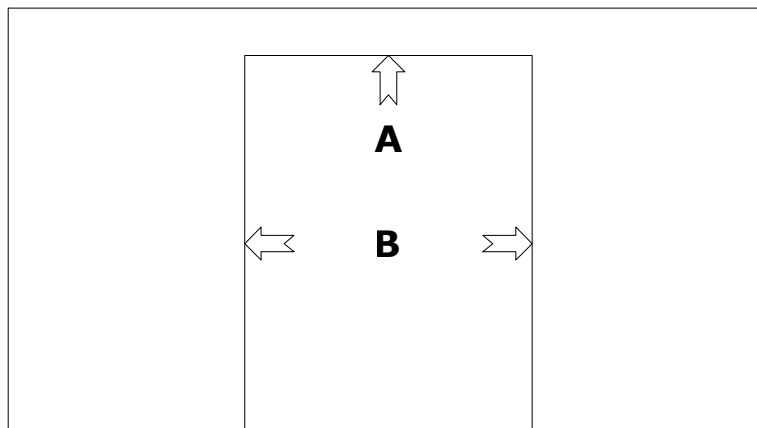

- Ⓘ APPLICAZIONE STUCCO O SCAGLIOLA
- Ⓔ APPLICATION OF PLASTER OR SCAGLIOLA
- Ⓟ APLICAÇÃO DE ALVENARIA OU GESSO
- Ⓒ NANÁŠENÍ ŠTUKOVÉ OMÍTKY NEBO SÁDROKARTONOVÉHO TMELU
- Ⓙ NANÁŠANIE ŠTUKOVEJ OMIETKY ALEBO SÁDROKARTONÁRSKEHO TMELU
- Ⓔ APLICACIÓN DE ESTUCO O ESCAYOLA
- Ⓝ AANBRENGEN VAN PLAMUUR OF GIPS
- Ⓕ APPLICATION DE L'ENDUIT POUR PLAQUE DE PLÂTRE
- Ⓓ AUFBRINGUNG VON GIPS (BAUSEITS)
- Ⓟ NAŁOŻENIE MASY GIPSOWEJ LUB TYNKU NA KRAWĘDZIE OŚCIEŻNICY
- Ⓔ НАНЕСЕНИЕ ШТУКАТУРКИ ДЛЯ ВНУТРЕННИХ ИЛИ НАРУЖНЫХ РАБОТ
- Ⓔ APLICARE TENCUIALA SAU IPSOS
- Ⓙ NANAŠANJE KITA ALI MAVCA
- Ⓔ VAKOLAT VAGY SCAGLIOLA GIPSMÁRVÁNY ALKALMAZÁSA
- Ⓕ NANOŠENJE ŠTUKATURA ILI GIPSANOG PRAHA
- Ⓕ TASOITUS- TAI RAPPAUSOHJE
- Ⓕ SIVA UYGULAMASI
- Ⓕ GLAISTYMAS

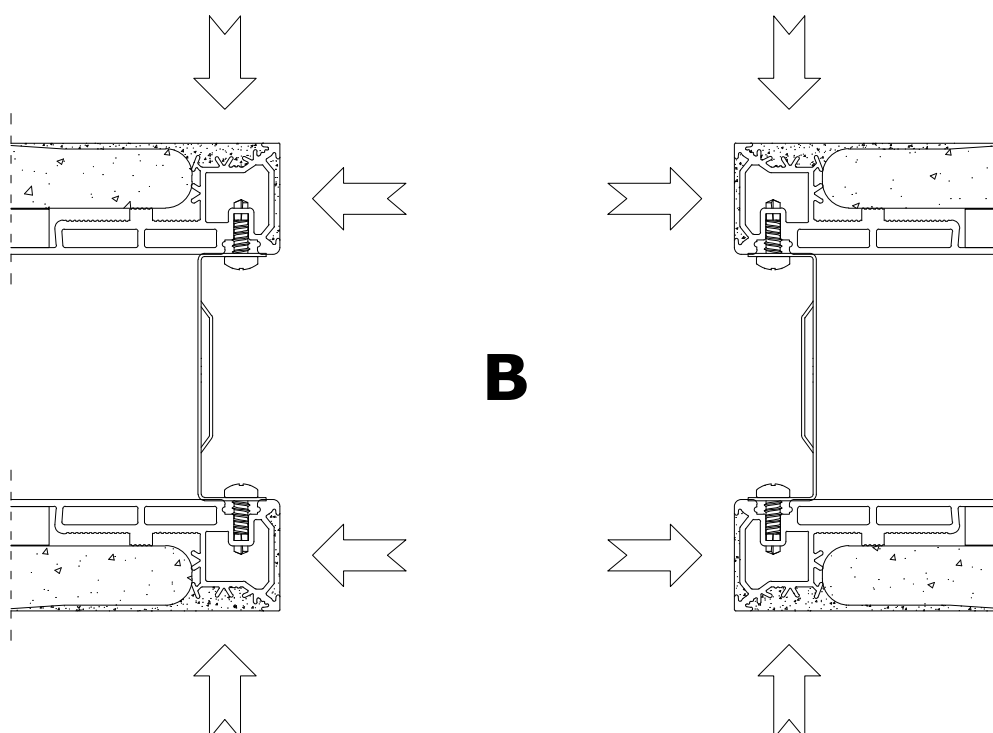
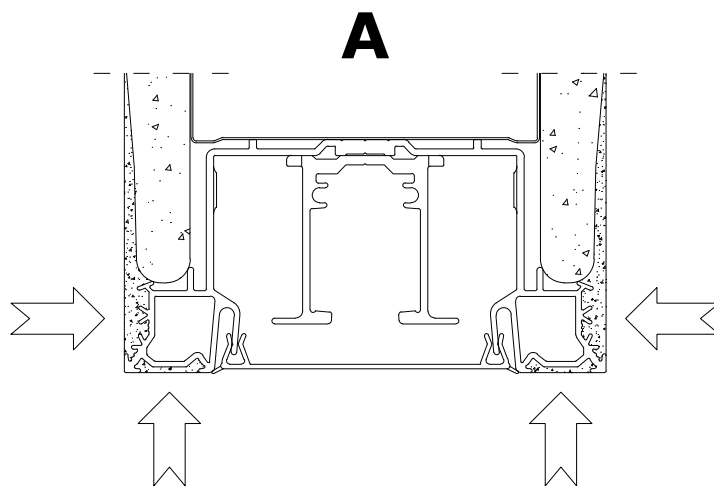

15

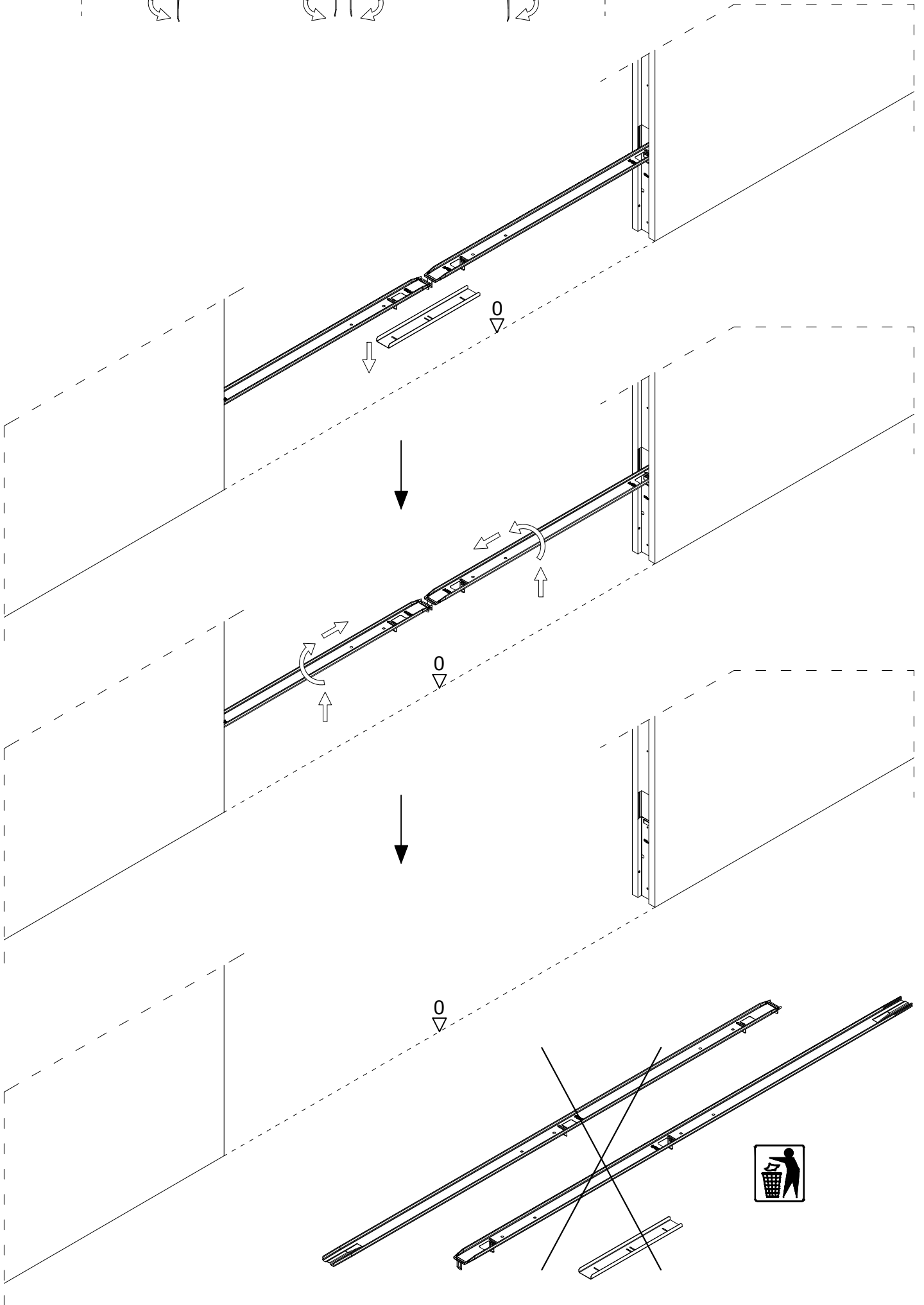
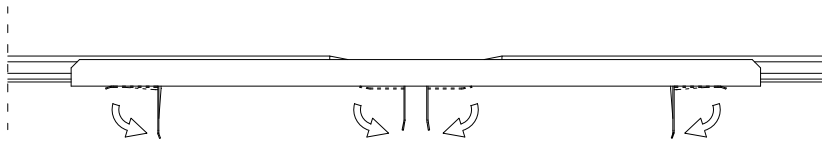



www.eclisse.com/en/dealer-locator

